

# The Advantage of Molded Foam in Product Design

## Rob Cole

Director of Sales

Protexic Brands

Tegant Corporation acquired by Sonoco Nov.2011

[Rob.cole@tegrant.com](mailto:Rob.cole@tegrant.com)

m. 248-245-0494

## David Meeker

Neoteric Product Development

Meeker@mit.edu

## Abstract

Although molded foam has long been used in packaging, it has continued to evolve in capabilities. This paper will explore a paradigm shift in use: employing it as the internal structure of a product rather than as packaging protection. By using molded foam internally as the structure of the product you automatically achieve significant DFMA results. Cost savings result from:

- Reduction in assembly time
- Reduction in screws and fasteners
- Reduction in disassembly time
- Reduction in service time
- Reduction in shipping packaging

These benefits extend to the indirect cost of product development as well:

- 50 % reduction in time & expenditure for product development
- 20 % more proto spins of product design
- Less costly tooling, shorter tooling cycles, less complex molds

## Setting The Stage

In the 1970's manufacturers discovered the need for peripheral equipment feeders and grippers to present parts so that a robot could place them appropriately in the product assembly. Boothroyd and Dewhurst did pioneering work in assembly automation in product design which included the analysis of parts for automated feeding. (Boothroyd, 1991) As the robotic revolution faded in the United States, analysis in the area of design for manufacturing and assembly (DFMA) shifted focus to the analysis of whole products and their constituent parts and subassemblies. If 70 – 80% of a product's final cost derives from materials, it stands to reason the

fastest way to reduce cost would be to eliminate parts/subassemblies.<sup>1</sup> Boothroyd and Dewhurst developed the concept of theoretical minimum part count<sup>2</sup> which serves as a goal for the product designer to achieve, yielding a design with the fewest part/subassemblies possible.

To determine if a part was a candidate for elimination a set of simple questions were developed.

### Test for Unnecessary Parts

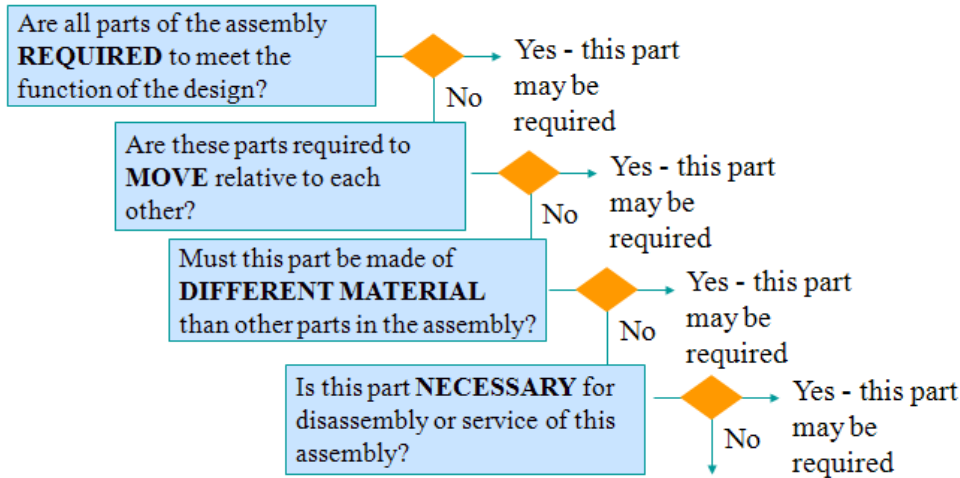

### Part is a candidate for elimination

If the answer to all of these questions is “NO” then this part is a good candidate for elimination. The exercise of how to design the product and hit the theoretical minimum part count was left to the imagination and creativity of the design team.



## THAT CREATIVE SPARK

When you look at a product design, many of its constituent parts, like brackets, fasteners, and sheet metal trays create internal structure. The only real purpose of the infrastructure is to hold together all the parts and subassemblies that need to be interconnected so that the product will function. As such, these parts are the ones most often highlighted for elimination when the theoretical minimum part count questions are asked. One of the earliest products to employ DFMA and the power of using theoretical part count was the IBM ProPrinter.<sup>3</sup> By using the theoretical minimum part technique as a target, IBM was able to eliminate all the fasteners, brackets and unnecessary pieces of hardware from its ProPrinter. In the ProPrinter, the base tray played a major role in fastener / bracket elimination. After redesign, every part in the ProPrinter fastened to the base tray via a snap fit, and subsequent parts snap fitted into parts already in place. In contrast, Epson’s PC printer the MX80 used a lot of hardware to fasten parts and subassemblies together and secure the final product assembly. As a result, the MX80 possessed 111 parts more than theoretical minimum, compared to three for the ProPrinter.

<sup>1</sup> Meeker, David and Nicholas Dewhurst. “DFMA and its Role in Cost Management” *The 20<sup>th</sup> Annual International Conference on DFMA* Warwick, RI June (2005)

<sup>2</sup> *Manufacture and Assembly 2<sup>nd</sup> edition*, G. Boothroyd, P.Dewhurst, W. Knight, Marcel Decker NY, NY, 2009. Pg’s 12 & 94

<sup>3</sup> *Design for Assembly in Action*, Assembly Engineering January 1987

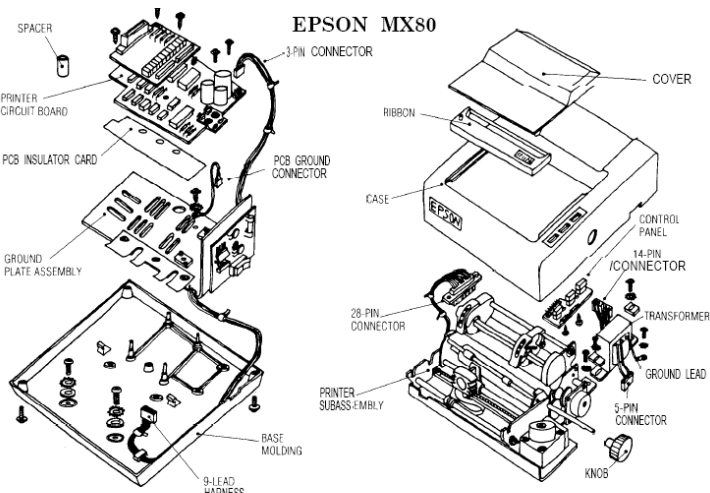

**FIG. 1**  
The EPSON MX80 dot matrix printer final assembly consists of 49 parts or subassemblies as shown in this exploded view.

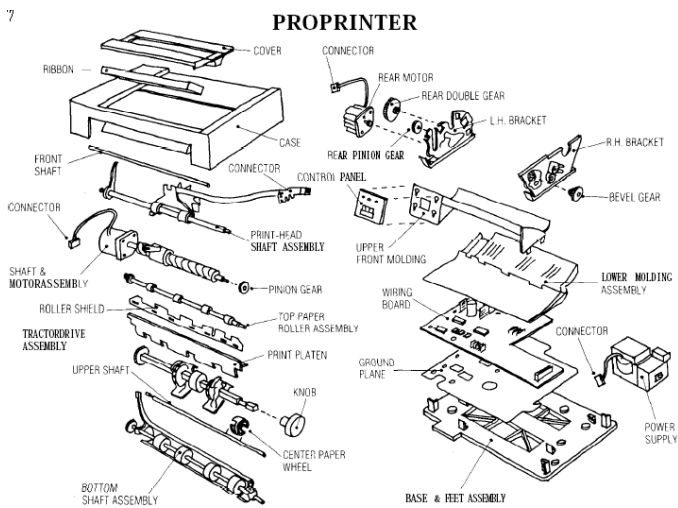

**FIG. 5**  
Exploded view of IBM Proprinter highlights design simplification in this product.

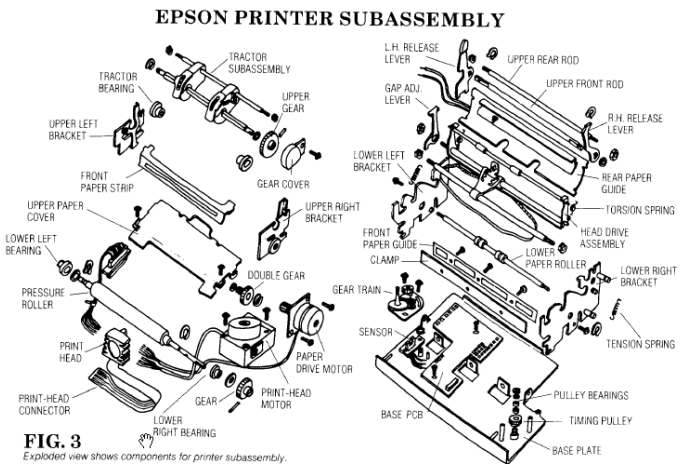

**FIG. 3**  
Exploded view shows components for printer subassembly.

| Epson MX 80                |       | IBM PRO Printer            |      |
|----------------------------|-------|----------------------------|------|
| Total Asm. time sec.       | 1866. | Total Asm. Time            | 170. |
| Total Number of operations | 185.  | Total number of operations | 32.  |
| Total parts/subs.          | 152.  | Total parts/subs.          | 32.  |
| Theoretical part count     | 41.   | Theoretical part count     | 29   |

**THE ORIGINS OF ELECTRONIC PACKAGING ASSEMBLY CONCEPT E-PAC**

Over time, competition caused Hewlett-Packard's workstation business to suffer from steadily decreasing market prices and shorter life cycles. The need for faster development and production times was critical. Faced with this challenge, the Hewlett-Packard Boblingen Mechanical Technology Center in Germany had to reduce the number of components in order to save time building the chassis, automate part mounting, and reduce overall chassis cost. In addition, HP needed to reduce logistics and administrative cost against tightening environmental protection guidelines.

## GENESIS OF AN IDEA

To achieve this, “The [product design] team could not get out of their minds the idea of fixing parts in such a way that they are enclosed and held by their by geometrical forms. The idea is similar to children’s toys that require them to put blocks, sticks, cards, or pebbles into matching hollows and at the same time keep track of positions and maintain a certain order at any time during the game”<sup>45</sup>

The critical step was finding a suitable material to achieve this since it needed to be:

- Pliable & Bouncy
- 100% recyclable
- Non conductive
- Able to hold tolerances
- Able to fix components without fasteners
- Able to have long term mechanical stability
- Heat and moisture resistant
- Resistant to chemicals

The material that seemed most suitable was expanded polypropylene (EPP). Fabricating the parts and assembling an existing workstation design to test foam concept only took 2 days. The big question was would it run? With only a few minor alterations for air flow, it not only ran, but passed all environmental tests as well. Compared to the traditional workstation, the **Electronic Packaging Assembly Concept (E-PAC)** workstation showed:

- 70 % reduction in housing parts
- 95 % reduction in screw joints
- 50 % reduction in assembly time
- 90 % reduction in disassembly time
- 30 % reduction in transport packaging
- 50 % reduction time and expenditure in housing development

Moreover, the E-PAC workstation included a number of additional benefits:

- Reduction in chassis parts
- One production step to produce molded parts
- Simple, fast, cost effective assembly
- Reduced product weight
- Good shock and vibration protection
- On spot cooling from air channels in the foam
- 100% recyclable material
- Reduced tolerance issues because of material flexibility

---

<sup>4</sup> HP-PAC: A New Chassis and Housing Concept for Electronic Equipment , J. Mahn, J. Haberle, S. Kopp,T. Schwegler *Hewlett-Packard Journal* Vol. 45, no.4, August 1994, p. 23-28.

<sup>5</sup> Product Design of the Model 712 Workstation and External Peripherals, A.L. Roesner *Hewlett-Packard Journal* April 1995, p.75-78.

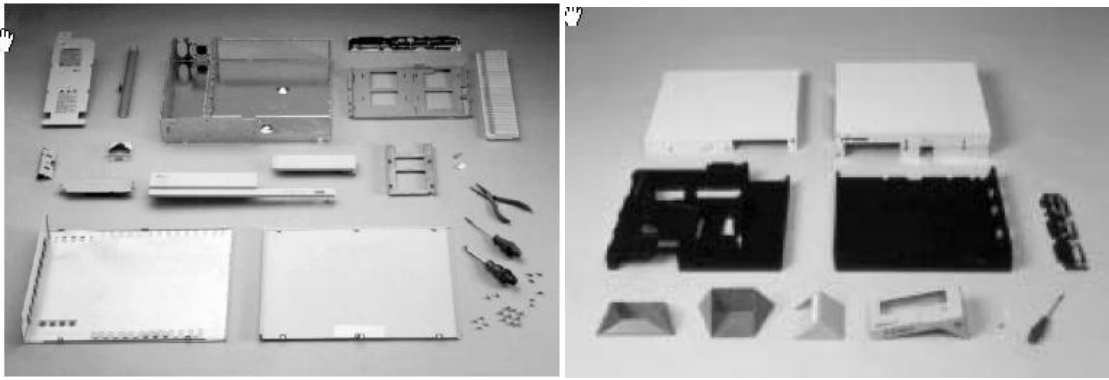
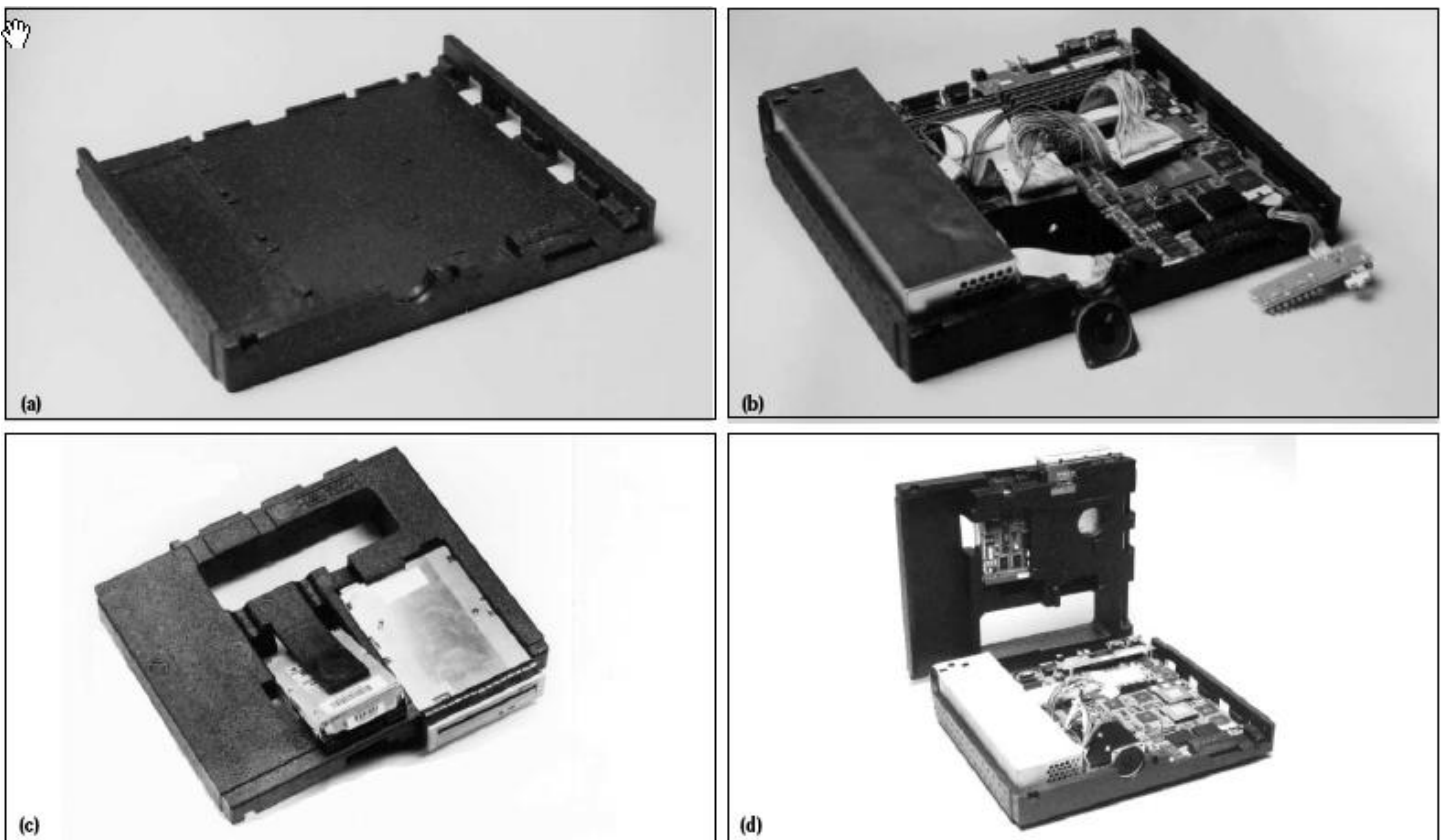
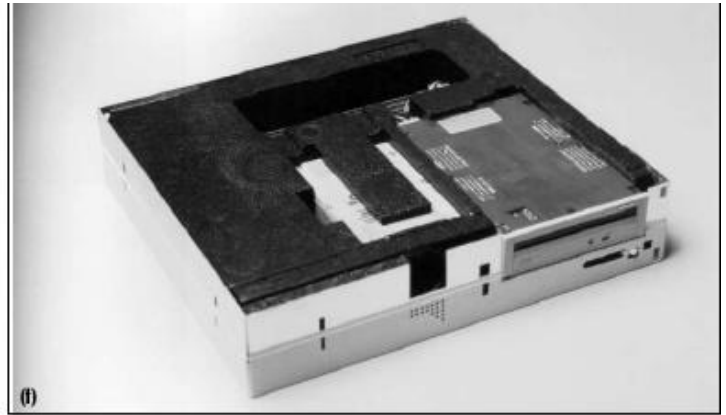

Fig.1 Difference between traditional chassis and E-PAC foam chassis

Fig.2 Is the sequence of building up workstation. ( below)





## **CASE STUDIES**

In 1994 HP pioneered and patented (# 5473507) E-PAC licensing it to DMT for further development. In the U.S., Tegrant began to manufacture products using the E-PAC approach. Since its creation, E-PAC has been used successfully in a variety of industries and applications to solve difficult design, manufacturing and cost challenges. Industry examples include; computer workstations, data storage systems, medical devices, consumer electronics, household appliances, industrial systems and automotive applications.

E-PAC yields dramatic DFMA results. The savings ripple through the entire product life cycle enabling low expenditure, rapid prototyping of the design, and relatively low cost tooling for the entire product. In many cases an entire product's foam parts can be made with one tool.

Other areas where E-PAC properties offer unique solutions to product design include but are not limited to:

- Major product cost savings in product design and manufacture
- Part count reduction
- Reduced assembly and disassembly time
- Reduced serviceability time

- Elimination of fasteners
- Sound absorption
- Sound transmission reduction
- Cooling efficiency
- Thermal and electrical insulation
- Vibration isolation and damping
- Tuning of sound and vibration
- Product weight reduction
- Reduction in shipping packaging
- RoHS Compliant -- No Phthalates -- CFC Free
- Excellent Chemical resistance
- 100 % recyclability
- Can meet many flammability requirements (UL, FMVSS, ASTM, etc.)

The case studies below show a number of different products that have been designed using expanded polypropylene and the E-PAC concept. Where allowed, specific results are shown.

## CASE STUDY 1 Oxymat 3 - Oxygen Deliver System

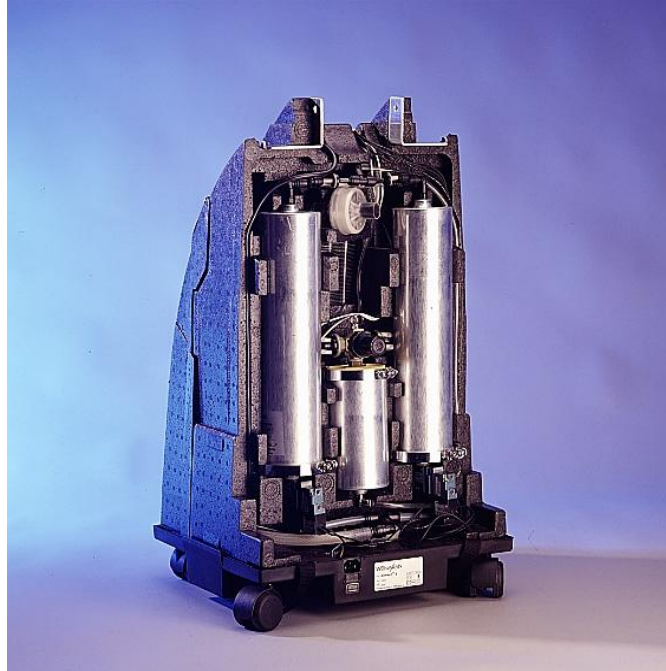
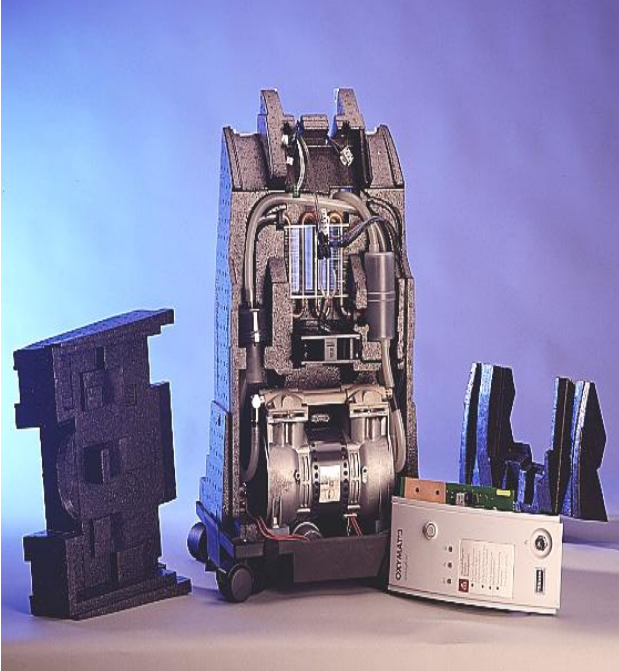

Developed by DMT



### **E-PAC Benefits**

- ✓ Fastener / bracket reduction 53 to 13
- ✓ Assembly time reduced
- ✓ Total part count reduced
- ✓ Substantial noise reduction
- ✓ Substantial reduction in service time



## CASE STUDY 2 Welch Allyn Medical Emergency Patient Monitor



### E-PAC Benefits

- ✓ Assembly time reduced
- ✓ Low cost tooling
- ✓ Replacement of all internal structure components
- ✓ Weight reduced
- ✓ Easy / fast access for service
- ✓ Product ruggedness increased

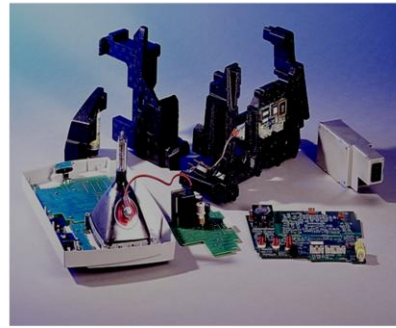
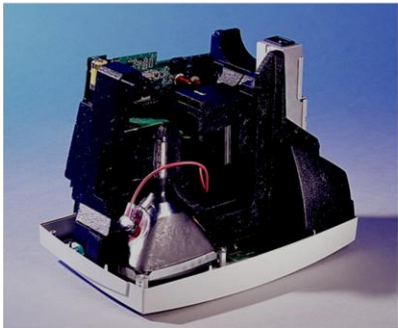

## Case Study 3 LifeBridge B<sub>2</sub>T Portable Heart Lung Device

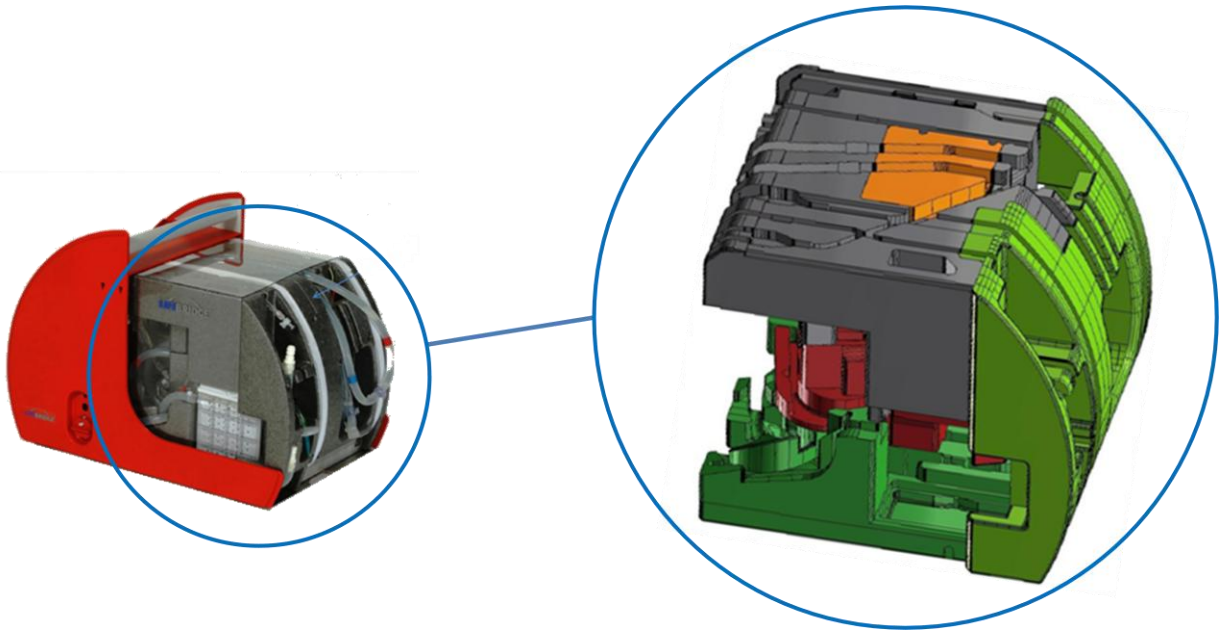

### **E-PAC Benefits**

- ✍ Significant weight reduction weighs only 17.5 Kg's.
- ✍ No fasteners
- ✍ Cables and tubes routed in the foam
- ✍ Recycling after use faster and no disassembly tools required
- ✍ Red Dot design award winner
- ✍ FDA approval in 2009

# CASE STUDY 4 Otis Elevator Next Generation Control System

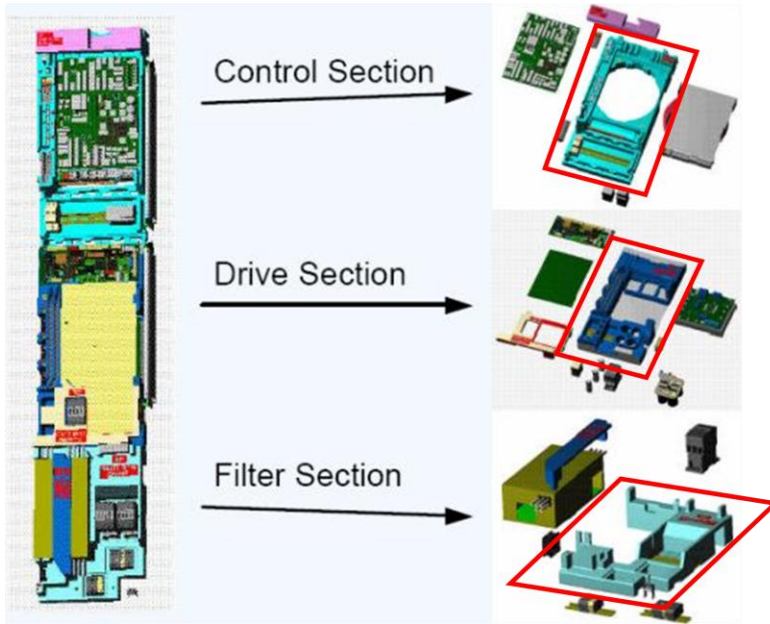

— E-PAC Component

## **Project Overview**

- ✦ New control system for next generation elevator

## **E-PAC Benefits**

- ✦ 81% reduction in volume
- ✦ 28% reduction in mass
- ✦ 68% reduction in assembly time
- ✦ 81% reduction in screws and fasteners
- ✦ 55% reduction in chassis parts

## CASE STUDY 5 Computer



### **E-PAC Benefits**

- ∅ 70% reduction in housing mechanical parts
- ∅ 95% reduction in screw joints
- ∅ 50% reduction in assembly time
- ∅ 90% reduction in disassembly time
- ∅ 30% reduction in transport packaging
- ∅ 50% reduction in engineering time for mechanical development of housing
- ∅ 50% reduction in weight of plastic

# Considerations for the Use of EPP in Product Design

EPP is classified as an organic polymer, one of a class of ethylene polypropylene copolymers that comes in the form of polypropylene beads. EPP can be formulated to have a wide range of densities; typical ranges are from 20 grams/liter to 225 grams/liter.

| PHYSICAL PROPERTY                                                        | TEST METHOD | UNITS                       | TEST RESULTS         |                      |                      |                      |                      |                      |                      |
|--------------------------------------------------------------------------|-------------|-----------------------------|----------------------|----------------------|----------------------|----------------------|----------------------|----------------------|----------------------|
| Density                                                                  | ASTM-D3575  | grams/liter                 | 20                   | 30                   | 45                   | 60                   | 67                   | 82                   | 90                   |
| Compressive Strength<br>@25% Strain<br>@50% Strain<br>@75% Strain        | ASTM-D3575  | MPa                         | 0.10<br>0.16<br>0.31 | 0.16<br>0.23<br>0.44 | 0.28<br>0.37<br>0.77 | 0.39<br>0.53<br>1.07 | 0.44<br>0.58<br>1.26 | 0.60<br>0.80<br>1.80 | 0.69<br>0.93<br>2.08 |
| Compression Set                                                          | ASTM-D3575  | %                           | 14                   | 12                   | 12                   | 11                   | 11                   | 10                   | 10                   |
| Tensile Strength                                                         | ASTM-D3575  | MPa                         | 0.26                 | 0.38                 | 0.46                 | 0.62                 | 0.71                 | 0.87                 | 0.97                 |
| Tensile Elongation                                                       | ASTM-D3575  | %                           | 15                   | 15                   | 14                   | 14                   | 13                   | 13                   | 12                   |
| Tear Strength                                                            | ASTM-D3575  | KN/m                        | 1.74                 | 2.13                 | 2.73                 | 3.25                 | 3.51                 | 4.07                 | 4.35                 |
| Flexural Strength                                                        | ASTM-D790   | MPa                         | .21                  | .38                  | .54                  | .72                  | .86                  | 1.08                 | 1.16                 |
| Flexural Modulus                                                         | ASTM-D790   | MPa                         | 9.8                  | 11.6                 | 14.5                 | 19.0                 | 22.2                 | 28.9                 | 31.1                 |
| Coefficient of Linear Thermal Expansion<br>20°C to -40°C<br>20°C to 80°C | ASTM-D696   | mm/mm/°C × 10 <sup>-5</sup> | 6.8<br>10.8          | 5.9<br>10.2          | 5.5<br>9.8           | 4.3<br>8.7           | 4.1<br>7.9           | 3.9<br>7.5           | 3.7<br>6.8           |
| Water Absorption                                                         | ASTM-C272   | gm s/cc × 10 <sup>-3</sup>  | 10.4                 | 8.1                  | 6.2                  | 5.1                  | 4.5                  | 4.2                  | 3.5                  |
| Flammability                                                             | FMVSS 302   | < 100 mm/min.               | Pass                 | Pass                 | Pass                 | Pass                 | Pass                 | Pass                 | Pass                 |
| Chemical Resistance<br>(Auto fuels, fluids, solvents)                    | Various     | 1 hr exposure               | Pass                 | Pass                 | Pass                 | Pass                 | Pass                 | Pass                 | Pass                 |

EPP after molding and tempering has very consistent dimensions. The material changes state at 140°C, thermal dissolution at 200°C, and ignition at 315°C. EPP in general is a good electrical insulator and can be coated with antistatic coating if necessary. In addition, humidity does not affect EPP's mechanical properties but it does absorb a small amount of water (see chart above.) Moreover EPP has excellent chemical resistance. It is also RoHS compliant, as well as free from CFCs and Phthalates. In addition, EPP can be treated with flame retardants; however, a good design can render flame retardants unnecessary.

## Flame Retardant Properties

- Un-modified bead can meet
  - FMVSS-302
  - UL-94 HBF ( 13mm wall thickness @ min. density of 60gm/l in std. black color)
  - UL-94 HBF ( 13 mm wall thickness @ min. density of 45gm/l in white color)
- Modified bead can meet
  - UL- 94 HF1 (7mm wall thickness @min. density of 45gm/l)
  - UL- 94 V0 (13 mm wall thickness @ min. density of 45gm/l)
  - ASTM-E84 Flame spread and Smoke development

For a complete listing of properties including sound absorption and well as design guidelines go to:  
<http://www.protexic.com/pdf/Protexic-EPP-Info.pdf>

# Material Processing Steps

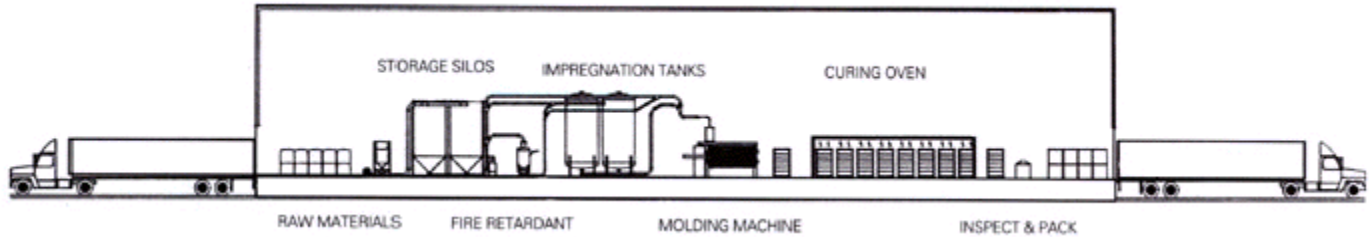

## 1. Receipt of Incoming Material

EPP is typically shipped in bulk via material handling trailer or in bulk containers

## 2. Raw Material Storage

EPP beads are conveyed by air from trailers to nylon mesh storage bags.

## 3. Impregnation

To obtain uniform internal cell pressure, the material is loaded into impregnation tanks and then subject to increasing air pressure. PLC controllers interfacing with pressure sensors control the rate of increase in pressure.

## 4. Molding

Molding machines are computer controlled to inject material into custom-built molds using either vacuum created injectors or by a technique referred to as counter pressure fill. During the counter fill, the material is introduced into the mold that has been pressurized to a value greater than the internal pressure of the material cells. As a result, the material is actually reduced in physical size, allowing it to flow more easily into thin wall sections. The process also increases part density and weight.

### EPP Molding Process

#### Storage Silo



#### Filling Device



#### Molding Press

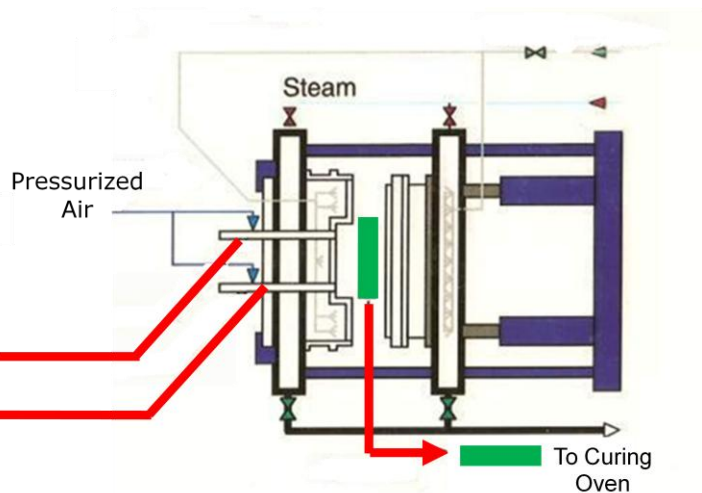

Once the mold has been filled, steam is applied for a controlled time and pressure, fusing the part. After fusing, the molded parts are cooled with water until the internal part pressure has stabilized and the parts can now be ejected from the machine. The time required for the fusion and cooling steps of the molding process lengthens as part density increases. During each molding cycle, the mold temperature cycles between 230 °F and 120° F.

### 5. Curing

Steam is used to transfer heat into the molded part. The part, once removed, begins to collapse as the steam trapped internally condenses. Over time, air migrates through the cell structure of the molded part, returning it to its original size and shape. Exposing the parts to heat (180 °F) for a consistent, controlled time accelerates their return to shape, since the cells become much more permeable with heat.

### 6. Inspection and Packing

Molded parts are removed from the curing oven and inspected for conformity to customer quality specifications. Parts that meet all the quality specifications are placed in cartons or reusable totes and shipped to the customer.

## Tooling

Due to the steam chest molding process, aluminum tooling is used to mold foam polypropylene into E-PAC parts. Tools can be cast or machined. Machined tools are used in the case of applications requiring complex shapes and tighter tolerances. Typically tools consist of two matched aluminum halves with wall thicknesses of 0.375 to 0.5 inches. This wall thickness provides the required strength, yet still facilitates heating and cooling during each molding cycle.

Multi-cavity tools allow 2 inches between cavities. The advantage of smaller machines is that they tend to hold tighter tolerances. The advantage of larger tools with multiple cavities is that part prices are lower. Cycle times tend to be between 1.5 to 2.5 minutes per cycle. Like injection molded parts, E-PAC parts should have uniform wall thickness. A typical E-PAC tool is shown below.



## Typical E-PAC Tool

Wall Thickness of Aluminum Tool is Typically 1/2"

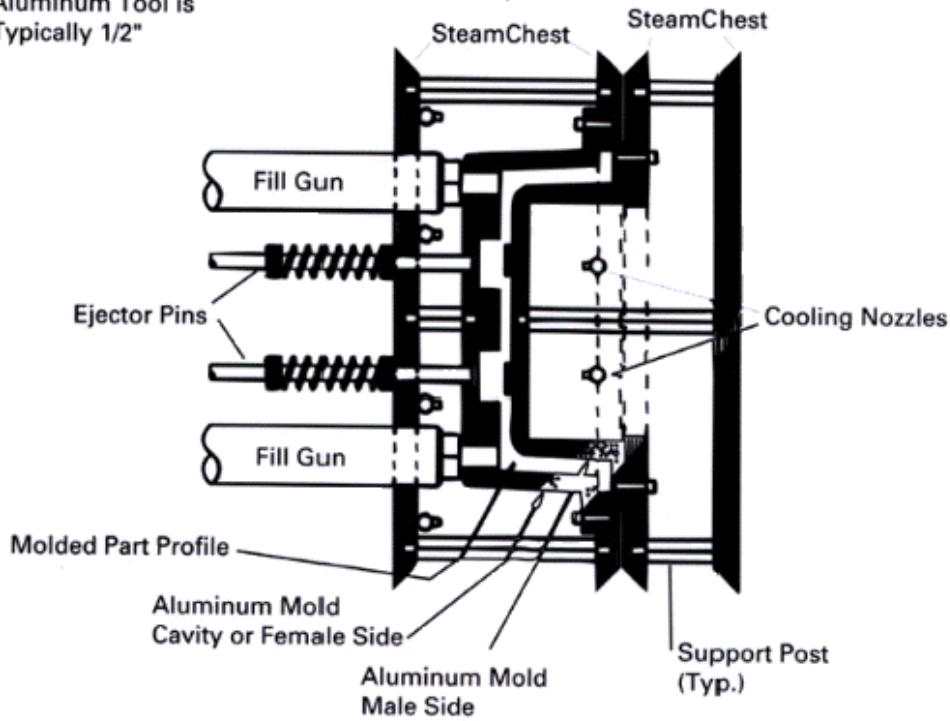

| Machine | Outside Dimensions | Maximum Part Size | Typical Tool Cost |
|---------|--------------------|-------------------|-------------------|
| K-68    | 31.5 X 23.6        | 27.6 X 19.7       | \$12K - \$25 K    |
| K-710   | 39.4 X 27.6        | 35.5 X 23.6       | \$15K - \$28K     |
| K-813   | 51.3 X 31.3        | 47.3 X 27.6       | \$18 K - \$35K    |
| K-1014  | 55.1 X 39.4        | 51.2 X 35.5       | \$25K - \$40K     |



## FASTENERS

If there is a need to use fasteners in your E-PAC design, there are a number of different ways to incorporate them. The examples below show a molded in place solution as well as an insert type.

Molded In Type Receiver Fastener

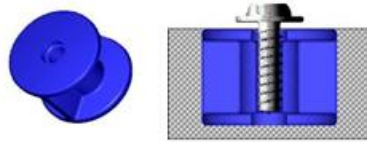

Inserted Blind Screw Type Fastener

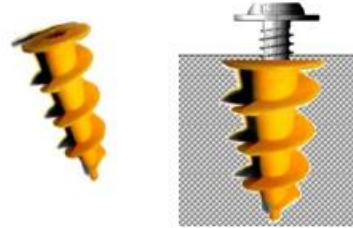

Spin-Welded Insert Fastener



Inserted Push Type Fastener



Auger Screw Blind-Hole Fasteners



Push-Type Blind-Hole Fastener



Inserted Screw Type Fastener



Inserted Push Type Receiver Fastener

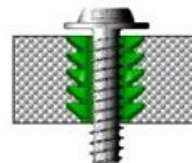

## Conclusions

The biggest challenge to overcome in successfully using E-PAC is taking the plunge. Capitalizing on the significant opportunities that E-PAC provides requires a paradigm shift. Because E-PAC allows quick prototyping, you can try out the concept on your existing design. By applying E-PAC, you achieve all the benefits of lower product cost, tooling cost, fewer parts, no fasteners, faster assembly times, quicker service times, lower product deployment cost and 100% recyclability.